

Federal Court



Cour fédérale

Date: 20171206

**Dockets: T-1741-13
T-1569-15
T-1728-15
T-2088-15**

Citation: 2017 FC 1111

Ottawa, Ontario, December 6, 2017

PRESENT: The Honourable Mr. Justice O'Reilly

Docket: T-1741-13

BETWEEN:

PACKERS PLUS ENERGY SERVICES INC.

**Plaintiff
(Defendant by Counterclaim)**

and

**ESSENTIAL ENERGY SERVICES LTD.
AND TRYTON TOOL SERVICES LIMITED
PARTNERSHIP**

**Defendants
(Plaintiffs by Counterclaim)**

Docket: T-1569-15

AND BETWEEN:

**RAPID COMPLETIONS LLC AND
PACKERS PLUS ENERGY SERVICES INC.**

Plaintiffs

and

BAKER HUGHES CANADA COMPANY

Defendant

Docket: T-1728-15

AND BETWEEN:

**PACKERS PLUS ENERGY SERVICES INC.
AND RAPID COMPLETIONS LLC**

**Plaintiffs
(Defendants by Counterclaim)**

and

**WEATHERFORD INTERNATIONAL PLC.
WEATHERFORD CANADA LTD.
WEATHERFORD CANADA PARTNERSHIP
AND HARVEST OPERATIONS CORP.**

**Defendants
(Plaintiffs by Counterclaim)**

Docket: T-2088-15

AND BETWEEN:

**PACKERS PLUS ENERGY SERVICES INC.
AND RAPID COMPLETIONS LLC**

**Plaintiffs
(Defendant by Counterclaim)**

and

**RESOURCE WELL COMPLETION
TECHNOLOGIES INC. AND RESOURCE
COMPLETION SYSTEMS INC.**

**Defendants
(Plaintiffs by Counterclaim)**

JUDGMENT AND REASONS

I. Overview

[1] This action is a consolidation of various proceedings involving the plaintiffs and defendants identified above. The parties are all companies involved in the oil and gas industry, most particularly, the extraction of hydrocarbons by a process called fracturing (or frac'ing). The action relates to a claim by the plaintiff Packers Plus Energy Services Inc that two of the defendants, Essential Energy Services Inc and Tryton Tool Services Ltd, have infringed Packers' Canadian Patent No 2,412,072 (the '072 patent) (Tryton is a division of Essential, and Essential assumes responsibility for Tryton, so I need only refer to Essential in these reasons.) Packers' claim against Essential has been merged with the collective defendants' counterclaims that the '072 patent is invalid. Separate proceedings on damages, if necessary, are scheduled to take place in early 2018.

[2] There are two main issues: infringement and invalidity, the latter consisting of several sub-issues. The issues may be summarized as follows:

1. Has Essential infringed the '072 patent?
2. Is the '072 patent invalid because:
 - (a) The subject-matter of the patent was previously disclosed?
 - (b) The subject-matter of the patent was obvious?
 - (c) The patent's claims lack utility?
 - (d) The specification of the patent was deficient?

[3] In my view, Essential has not infringed the '072 patent either directly or in concert with others. Further, Essential did not induce others to infringe the patent. In addition, I find that the patent is invalid because the invention was previously disclosed and for obviousness; the subject matter of the claims in issue did not represent an inventive step compared to the state of the art at the relevant time. Therefore, I must dismiss Packers' claim of infringement and grant the defendants' counterclaim of invalidity.

II. The '072 Patent

A. *The Disclosure and Claims*

[4] Packers filed the '072 patent on November 19, 2002, citing a prior US patent filed a year earlier, November 19, 2001. The patent will expire on its Canadian 20th anniversary, November 19, 2022.

[5] The '072 patent, owned by Packers, is entitled "Method and Apparatus for Wellbore Fluid Treatment". The named inventors are Mr Jim Fehr and Mr Daniel Themig. Mr Themig has occupied a number of positions with Packers since he helped found the company in 2000; he is currently its CEO and Chief Technology Officer. Mr Themig testified at length in this action, and I will cite his evidence extensively, especially in my discussion of the subject matter of the patent and the events leading up to its filing.

[6] The patent describes the field of the invention as being a method and apparatus for wellbore fluid treatment and, "in particular, ... for selective communication to a wellbore for

fluid treatment”. This description refers to a means of sending fluids to selected, isolated areas of a wellbore. The patent explains that it is sometimes necessary to “stimulate” the wellbore by pumping fluids into it in order to improve the flow of petroleum products out of it. The fluids include fracturing fluids, and one method of stimulating a wellbore is fracturing. Essentially, fracturing involves sending fluids down a wellbore at pressure high enough to break the adjacent rock formation, enabling hydrocarbons to be released from the fractured formation.

[7] The patent summarizes some of the prior art relating to stimulation of isolated segments of a wellbore. It also describes the use of tools called “packers” to achieve isolation, and explains the drawbacks of setting and moving packers sequentially for that purpose: it takes time and it is expensive.

[8] The invention, says the patent, allows selective communication (*ie*, transmission) of fluids to different segments of a wellbore by way of a tubing string consisting of a series of packers and ports. The packers extrude (*ie*, expand) against the wellbore in order to create segments along its length, each of which contains a port and sliding sleeve mechanism, allowing each segment to be operated independently. Each port is opened by way of a plug or ball sent down the tubing string to land on a seat connected to a sliding sleeve that pushes open the port. The apparatus and methods of the invention, according to the patent, can be used in a variety of wellbores, including “open holes, cased holes, vertical holes, horizontal holes, straight holes or deviated holes.”

[9] The patent states that the packers could be of any desired type that would create a seal between the wellbore and the tubing string. The patent makes reference to “solid body” packers, which would be preferable in an open hole versus a cased hole. The patent defines these packers as including a “solid, extrudable packing element” and “a plurality of extrudable packing elements”.

[10] In sum, by way of these components and techniques, the patent provides a method for fluid treatment of a wellbore. The method consists of a tubing string, situated along the long axis within the wellbore, which contains ports that are opened by way of sliding sleeves, and that allow fluids to pass through the ports to the wellbore. The packers extrude against the wellbore to isolate segments of it, with each segment containing a port and sliding sleeve mechanism.

[11] Annex A contains a diagram taken from the patent (Figure 1a) that depicts a series of packers, ports, and sliding sleeves. The parties found it convenient to refer to the method shown in this diagram as the “ball-drop system”.

[12] The patent sets out 162 claims. Only claims 96 to 111 are in issue here.

[13] The principal claim is claim 96. It claims the method described above – a means for fracturing a hydrocarbon-containing formation in an open hole using a tubing string essentially consisting of a series of packers, ports, and sliding sleeves. The claim provides more details of the various components and actions that make up the method of the invention including:

- A first port that creates an opening in the tubing string wall;

- A second port, further downhole from the first, that also makes an opening in the tubing string wall;
- A first sliding sleeve of a diameter that, when the first port is closed, allows fluid to pass down the tubing string, and when the first port is open, allows fluid to pass through the port to the wellbore;
- A second sliding sleeve with a diameter smaller than the first, which operates similarly to the first sleeve;
- A first solid-body packer mounted on the tubing string uphole from the first port and capable of making a seal between the tubing string and the wellbore;
- A second solid-body packer mounted on the tubing string between the first and second ports and also capable of making a seal between the tubing string and the wellbore;
- A third solid-body packer mounted on the tubing string on the opposite side of the second port from the second packer;
- A tubing string run into the wellbore with the packers in an unset position;
- The three packers expanding outward and creating seals against the wellbore wall in an open hole, securing the tubing string in place. The packers create annular spaces between the tubing string and the wellbore wall and do not permit fluids to move between the annular spaces, but do allow fluids to communicate with the formation within those annular spaces; and
- Sending a fluid-conveyed sealing device down the tubing string, passing through the first sliding sleeve and landing on the seat of the second sliding sleeve, moving the

second port to the open position and allowing fracturing fluids to flow through that port into the annular space defined by the packers.

[14] The remaining claims in issue (97-111) amount to minor dependent variations on claim 96. I need not describe all of them. Claim 98 specifies that the packers may be set hydraulically. Claim 103 refers to a variety of potential fracturing fluids, including acid, water, oil, carbon dioxide, and nitrogen. Claims 110 and 111, respectively, state that the sealing device may be a plug or a ball.

B. *Construing the Claims*

[15] Claims are meant to be construed purposively from the perspective of the ordinary skilled person within the field of the invention. The parties essentially agree that the skilled person is a petroleum or mechanical engineer, having between two and five years' field experience.

[16] The claims are straightforward. They relate to a series of components of the so-called "ball-drop system" – tubing string, packers, ports, sliding sleeves, and sealing devices (plugs or balls) – which are put to use in performing a method of liquid fracturing of an open-hole wellbore.

[17] There are only two points of controversy between the parties relating to the construction of the claims. First, what is meant by the phrase in claim 96 that "the first, second and third solid body packers when expanded, secure the tubing string in place in the wellbore". Second, does claim 96's reference to "solid body packers" include swellable packers?

[18] On the first issue, Essential offered Mr Michael Chambers' expert evidence to the effect that the word "secure" in claim 96 means that the packers ensure that, by firmly fixing it in place, the tubing string "cannot be moved". Mr Chambers conceded on cross-examination, however, that the claim does not state that the tubing string will not move at all.

[19] Packers' expert, Dr Jennifer Miskimins, interpreted the word "secure" to mean that the packers will stop the tubing string from moving up and down the wellbore. She testified that a packer that extrudes against the wellbore achieves isolation in the system but also "is holding the whole system in place." A skilled person, in her view, would understand that the packers would secure the tubing string "sufficiently" to allow a successful selective fracturing operation to be carried out. She testified that there "might be a small amount of leaking" of fluids from one segment to another, but the skilled person "would understand that that small amount of leaking is not going to inhibit the successful hydraulic fracturing treatment."

[20] I agree with Dr Miskimins' opinion. I believe a skilled person would understand the role that packers play in the method described in the patent. The packers create a seal that allows sections along the wellbore to be fractured separately. In addition, they hold the tubing string in place to ensure that the fracturing occurs at the desired location. A skilled person would understand the importance of selecting packers that would perform those two interrelated functions. A packer that did not create a proper seal would be unlikely to prevent the tubing string from moving along the wellbore.

[21] Therefore, interpreting the patent purposively, I would construe claim 96 as extending to packers that are capable of creating a reliable seal against the wellbore and ensuring that the tubing string is effectively held in place. I would not interpret the claim as requiring that the packers completely immobilize the tubing string. Some inconsequential movement would still permit an effective selective fracturing operation to be performed.

[22] With respect to the second issue, Essential argues that the term “solid body packer” in claim 96 does not include a swellable packer. The difficulty is that, according to a number of witnesses, the name “solid body packer” is not well known or accepted in the industry. Mr Chambers, for example, said that he is “unaware of any plain and ordinary meaning for the term ‘solid body packer’” and felt that the term is “too ambiguous to be construed.” Similarly, Essential’s witness, Mr Wes Lyster, was unfamiliar with the term “solid-body packer.” How, then, would the skilled person, probably unfamiliar with the term, interpret it?

[23] Essential relies on Mr Chambers’ opinion that a skilled person would likely consider a solid body packer to be a packer that is set hydraulically or mechanically by way of a compressive force against a solid extrudable element, such as rubber. The force would cause the element to expand outward, creating a seal against the wellbore.

[24] Essential also submits that a swellable packer is not a solid body packer. A swellable packer consists of material that expands when exposed to a liquid. When that material is held between two fixed points, it will extrude outwards. The main difference between a swellable packer and a solid-body, hydraulically-set packer is that the source of the force causing extrusion

in a swellable packer is generated from within the packing element, not from without. Essential argues that a swellable packer cannot meet the definition of a solid-body packer because its packing element is not squeezed outward by an external force. In addition, a swellable packing element is not compressed – its linear external dimensions never change.

[25] Essential points to a number of sources that it says support its argument that swellable packers are not solid-body packers. These include:

- One of Packers’ US provisional patent applications defines a solid-body packer as one which is extruded either mechanically or hydraulically;
- Mr Themig’s testimony that a solid-body packer is “compressive loaded” and “typically loaded primarily axially”;
- Mr Chambers’ statement that a solid-body packer contains elements that are “linearly compressed and extruded” by a “compressive force” that is generated hydraulically or mechanically; and
- On cross-examination, Dr Miskimins’ testimony that, with swellables, there is a compressive force, but not one that is applied externally or hydraulically.

[26] I am persuaded by Dr Miskimins’ opinion on this point. Dr Miskimins stated that a solid-body packer has a solid element that could either be hydraulically set or swellable. It would not include, however, an inflatable packer, which expands when filled with fluid. On the latter point, all experts agreed.

[27] Under cross-examination, Dr Miskimins explained that swellable packers do not extrude by applying a compressive force on them as is the case with hydraulically-set packers. However, she also stated that “there is a compressive force there, but we are not necessarily setting it by compression We are not forcing it by putting compression on it.”

[28] I accept the contention that swellables are different from hydraulically-set packers. However, I cannot conclude that the differences are sufficient to classify the latter as solid-body packers and the former as not.

[29] The relevant question is whether the packer contains a solid element. Inflatable packers, whose elements expand balloon-like when infused with a liquid, are therefore not solid-body packers. On the other hand, swellable packers, whose elements expand sponge-like in the presence of a liquid, can be considered solid-body packers.

[30] Further, given that the term “solid body packer” has no well-accepted definition, I see no reason why the skilled person would interpret it as including packers that extrude as a result of an externally-generated, hydraulic or mechanical compressive force, but excluding packers that extrude as a result of an internally-generated, absorptive compressive force. In both cases, the extruding element is a solid. As Dr Miskimins’ explained in her testimony, the packing element on a swellable packer “is just solid, but it swells out against the casing and so it holds that area, it swells out enough that it holds the area from the tubing string out to the casing string itself.”

[31] Accordingly, a skilled person would consider the term “solid-body packer” to include a swellable packer.

[32] Therefore, I construe claim 96 to include packers that create a seal against the wellbore and hold the tubing string securely enough to enable selective fracturing. In addition, the “solid body packers” referred to in claim 96 include swellable packers that extrude against the wellbore as a result of a compressive force originating in the solid absorptive packing element.

III. Issue 1 – Has Essential infringed the ‘072 patent?

[33] Essential concedes that when its system is used in an open-hole fracturing job, all the steps of claims 96 to 109, and 111 will have been performed.

[34] However, Essential argues that it has not infringed the ‘072 patent because there is no evidence showing that its packers secure the tubing string in place in an open-hole wellbore. In addition, it maintains that its swellable packers are not “solid body packers”.

[35] Further, Essential submits that it does not perform the core elements of the patent and, therefore, cannot be found to have infringed it.

[36] Finally, Essential contends, contrary to Packers’ allegation, that it has not acted in concert with others to infringe the patent; nor has it induced others to infringe the patent.

[37] I have already construed claim 96 of the patent to include packers that secure the tubing string sufficiently in place to enable successful selective fracturing. In addition, the claim includes swellable packers.

[38] Based on that construction, it is clear that Essential's equipment, called the Tryton Multi-Stage Fracturing System (Tryton MSFS), infringes the '072 patent when used in an open-hole fracturing operation. In the circumstances, it is unnecessary to provide any more than a brief description of that equipment. A detailed description is set out in an expert report by Dr Miskimins, in which she concludes that all of the steps of claim 96 of the '072 patent are followed when using the Tryton MSFS to fracture isolated zones of an open-hole wellbore. Further, she concludes that the remaining claims in issue are also infringed depending on the choice of packers and sleeves within the Tryton MSFS (other than claim 110, which refers to a plug rather than a ball).

[39] Promotional information for the Tryton MSFS describes it as allowing "producers to isolate and fracture several intervals of the horizontal section of a well separately and continuously." It goes on to state that the MSFS "is a 'ball and seat' system in which downhole sleeves are opened in sequence by dropping progressively larger synthetic balls through a liner to allow precise fracs to occur in stages along the non-cased horizontal leg of a well." In other words, the Tryton MSFS is a ball-drop system used for selective fracturing of a horizontal open-hole wellbore.

[40] The evidence shows that Essential's fracturing system secures the tubing string in place with either hydraulic or swellable packers. Essential argues that it employs an additional, intermediate packer to secure the tubing string which is not contemplated by the '072 patent. Mr Wes Lyster, an Essential employee, testified that this intermediate packer (the "liner/hanger packer") "helps hold the system in place."

[41] However, Dr Miskimins explained that the packers in the Tryton MSFS have extrudable elements that seal against the tubing string and the wall of the open hole wellbore. That seal holds the tubing string in place and creates zones of isolation between the packers. She testified that the Tryton MSFS packers "create these isolated zones so that we can then hydraulically fracture those isolated zones." Mr Lyster agreed that the packers hold the string in place at least "a little bit."

[42] The Tryton MSFS consists of a variety of available packers, most of which are hydraulically set (*eg*, the "IsoPac I" and "IsoPac II"), but one of which is swellable (the "SwellRight"). In reality, Essential has never actually used or sold swellable packers, although it offers them for sale. In any case, Dr Miskimins concludes that the Tryton MSFS follows the steps of claim 96 whichever packers are chosen. They are all solid-body packers, in her view.

[43] I have already discussed and set out my agreement with Dr Miskimins on this point. The term "solid-body packer" includes packers that are hydraulically or mechanically set, as well as swellable packers. Accordingly, when put in use in an open-hole fracturing operation, the Tryton MSFS falls within the relevant claims of the '072 patent (except claim 110).

[44] Essential next argues that it cannot be found to have infringed the patent because it is simply not engaged in the key activities involved in fracturing. In particular, Essential does not decide whether a formation should be fractured or whether to complete an open-hole versus a cased-hole wellbore. Essential points out that the relevant claims relate to a method of fracturing a formation, not the equipment itself. Therefore, according to Essential, Packers must prove that Essential has actually worked the method of the patent – that is, that it has carried out a fracturing operation using the teachings of the alleged invention – not merely sold the components of the ball-drop system.

[45] Packers maintains that Essential has infringed the patent even though it has not conducted any fracturing. Packers says that Essential is liable for having jointly committed infringing activities with other companies in the fracturing industry. Alternatively, Packers contends that Essential induced others to infringe the '072 patent.

[46] I disagree with Packers.

[47] I first note that Dr Miskimins does not conclude that Essential has infringed the '072 patent. Rather, she carefully opines that use of the Tryton MSFS would include all of the steps set out in the patent's claims. She does not provide an opinion on liability for infringement.

[48] In terms of liability for acting in concert with others, Packers has not pointed to any legal support for that theory of liability. Packers points to the well-known English case of *Fabio Perini SPA v LPC Group PLC & Ors*, [2009] EWHC 1929. There, Justice Floyd found that a company

that installed a machine on the defendant's premises and enabled it to be operated according to the patented method was jointly liable with the defendant for infringement (at para 179). That finding was cited, in *obiter*, by Justice Johanne Gauthier in *Bauer Hockey Corp v Easton Sports Canada Inc*, 2011 FCA 83 at para 75. However, there is no authority in Canadian law for the proposition that a person can be found liable for infringement on the theory of common design. At common law, however, parties who act in concert to commit a tortious act can each be found liable if all of the parties involved arrived at an agreement to carry out the tort (*Sea Shepherd UK v Fish & Fish Ltd*, [2015] UKSC 10 at para 40).

[49] However, there is simply no evidence showing any such agreement between Essential and the other companies with whom it acted – operating companies, drilling companies, or fracturing companies. Therefore, Essential cannot be found liable for infringement based on a common design.

[50] Packers also alleges inducement. The parties agree that a plaintiff alleging inducement must satisfy a difficult test requiring proof of three distinct elements: (1) direct infringement by a third party; (2) the defendant influenced the third party to the point that the infringing act would not have occurred without that influence; and (3) the defendant knew that its influence would bring about the infringing act (*Corlac Inc v Weatherford Canada Ltd*, 2011 FCA 228 at para 162).

[51] Packers has not produced evidence of direct infringement by anyone. It merely implies that Essential's main customers, the operating companies who own and operate the wells, are the

infringers. However, the evidence shows that there are often numerous entities involved in a fracturing job, including the operating company and the various service entities it hires – drilling companies, pumping companies, cementing companies, tool companies, and fracturing companies. It is unclear who the direct infringer would be in that situation.

[52] Packers also refers to evidence of Essential's involvement in fracturing jobs. Essential's role includes:

- Pre-installation planning and design;
- Assembling, installing and operating the equipment, including setting the packers;
- Supplying and loading the balls;
- Providing an on-site supervisor, who would have access to data relating to the fracturing job; and
- Conferring with the operating company on any problems that arise;

[53] However, Mr Lyster emphasized that the main decisions at the well-site are made by the operating company, not Essential. Those decisions include:

- Whether to fracture;
- Whether to drill horizontally;
- Whether to complete the well in an open hole;
- Whether to employ a ball-drop system;
- The scheduling of the fracturing job;
- The number of zones to treat;
- The length of each zone;

- The placement of the packers and sleeves;
- The pressures to use;
- The type of balls to launch; and
- The kinds of fluids to pump.

[54] Further, according to Mr Lyster, other service companies perform important actions during the fracturing operation, including the pumping company (applying the pressure to set the packers and open the sleeves), the fracturing company (choosing the fluids and pressures), and the ball-launcher company (choosing and launching the balls). During the actual fracturing, Essential's representative is mainly an observer, helping to troubleshoot, if necessary.

[55] Perhaps the collectivity of companies involved in a fracturing operation could be said to work the method claimed in the '072 patent. However, each of their respective contributions to the operation would amount to a partial or, at most, an indirect infringement, not a direct infringement of the patent. Therefore, Packers cannot meet the first branch of the test for inducement. It has not proved direct infringement by anyone.

[56] With respect to the second branch, Packers notes that there are many ways in which Essential can influence a potential infringer. Essential advertises its wares, makes sales calls, prepares job proposals, makes presentations, and indemnifies its clients against patent infringement suits. Packers points to a price quotation Essential provided to a customer and infers that Essential and the customer probably discussed the product and that Essential probably tried to persuade the customer to buy its equipment.

[57] This is speculation. Packers has provided no evidence that Essential's conduct had any impact on any alleged infringer's actions. Indeed, the evidence shows that Essential's clients influenced Essential to develop its Tryton MSFS methodology. Other companies were already selling ball-drop systems for open-hole fracturing. To remain competitive, Essential decided it should offer a similar technology to its customers. Those customers were familiar with and already using competitors' ball-drop systems.

[58] Further, there is no evidence that, absent Essential's influence, direct infringement of the '072 patent would not otherwise have occurred. Essential may have persuaded some companies to purchase its tools, and some of its personnel have attended at fracturing sites to help troubleshoot. However, those activities did not amount to the degree of influence required to prove inducement.

[59] Finally, there is no evidence that Essential knew that its influence would result in the carrying out of infringing acts.

[60] Accordingly, Packers' claim of infringement is unfounded.

IV. Issue 2(a) – Is the '072 patent invalid because the subject-matter of the patent was previously disclosed?

A. *Overview*

[61] A patentee merits a monopoly only when the claimed invention is truly new, useful and unobvious.

[62] Generally, an invention cannot be considered new if it had already been publicly disclosed and the disclosure provided enough information to enable a skilled person to use it. The defendants claim that Packers disclosed the subject matter of the '072 patent a number of times during the relevant period (that is, before November 19, 2001, one year before the filing date of the patent: *Patent Act*, RSC 1985, c P-4, s 28.2(1)(a)).

[63] Packers concedes that the invention described in the '072 patent may have been disclosed prior to the critical date. However, it maintains that those disclosures related either to experimental testing of the invention, or were made to persons who had a duty to keep them confidential. Therefore, says Packers, the disclosures fall within well-known exceptions to the general rule.

[64] I disagree with Packers. Mr Themig, of Packers, disclosed his claimed invention to customers before November 19, 2001. His disclosures did not occur in circumstances involving experimental testing of the ball-drop method, or requiring that the recipients keep the information confidential.

B. *The Disclosures*

[65] The evidence relates to Packers' involvement in three US mine sites in the autumn of 2001. The first two, called Garner and Noelke, were operated by a company called Enron Oil and Gas (EOG). The third, called Dynneson, was owned by Headington Oil.

[66] Most of the relevant factual evidence comes from Mr Themig. His story relates the origin of the ideas reflected in the '072 patent, his involvement in the EOG and Headington projects, and the history of his company, Packers.

[67] Mr Themig described Packers as a high-end provider of downhole tools, particularly for purposes of fracturing horizontal, open-hole wells. Packers markets the method claimed in the patent under the name StackFRAC (and later, StackFRAC HD). Mr Themig maintained that the method described in the '072 patent transformed the industry, enabling operators to conduct multi-stage fracturing jobs with up to 70 isolated segments.

[68] Mr Themig confirmed that Packers' first use of its StackFRAC system was at EOG in the autumn of 2001. That work came about after Packers had carried out high-pressure, open-hole water shut-off operations in North Dakota using solid-body packers. The packers were used to isolate sources of water and to prevent water from mixing with oil coming out of the wellbore. Somehow, in August 2001, an employee at EOG, Mr Gary Thomas, found out about Packers' North Dakota work and wanted to discuss it with Mr Themig. Mr Thomas visited Mr Themig in Calgary and described EOG's gas well operation in Midland, Texas. The two men discussed various ways of completing the wells and, a week or two later, EOG invited Mr Themig to meet its engineers in Midland for further discussions.

[69] Before the Midland meeting took place, Mr Themig received a fax dated August 17, 2001 from another EOG employee, Mr Glenn Carter, who provided some additional background information. The fax explained that EOG was carrying out fracturing jobs that were generating

good production but only for a short period of time. Mr Carter stated that EOG was interested in drilling dual lateral wells, fracturing each leg separately, and using open-hole, resettable packers to perform smaller treatments in each lateral.

[70] Mr Themig travelled to Midland in late August 2001 and, en route, sketched out a few ideas that he intended to share with EOG. Mr Themig met with Mr Carter on August 29, 2001. They agreed that Mr Themig would present his ideas to a larger group the next day, and that the information flowing between Mr Themig and EOG would be treated as confidential, in both directions. Mr Themig assumed that Mr Carter had the authority to make that commitment on behalf of EOG; he did not specifically ask him. The discussion of confidentiality was general and brief – it did not address, for example, the duration of the parties' commitments, the treatment of confidential documents, or the remedies that would be available in case of a breach.

[71] On August 30, 2001, Mr Themig met with EOG's geologists, reservoir engineers, drilling engineers, and completion engineers – a group of between 12 and 20 people, some of whom may have come and gone over the course of the day. Mr Themig was not sure if the participants were all EOG employees or whether some of them might have been contractors or consultants. Mr Themig learned more about EOG's wells and proceeded to present his sketches of potential strategies for increasing production. One of the last drawings depicted a series of solid-body packers (Packers' RockSEALs) in an open-hole horizontal well, combined with hydraulic ball-activated ports – in effect, the ball-drop system, later known as the StackFRAC. Mr Themig described how the system worked. EOG saw that the benefit of this approach was that it permitted fracturing of multiple segments of the wellbore without having to move tools from one

position to another. While Mr Themig believed he was describing a system that was novel in the industry, he is not sure there was any discussion at that meeting of confidentiality. As mentioned, that subject had been addressed in his verbal exchange with Mr Carter the day before. The parties did not enter into a written confidentiality agreement.

[72] After Mr Themig returned to Calgary, Mr Carter called him to organize a visit by EOG personnel to Canada to look at Packers' tools and meet some of Packers' customers. Mr Themig sketched out a fracport tool so that it could be built and tested before EOG's arrival. Mr Themig took the EOG representatives to Edmonton to see Packers' manufacturing site and to witness some testing of Packers' tools, including the fracport tool. The meeting was a success; Packers entered into a contract with EOG for downhole tool services and supplied tools for use on two EOG wells, the Garner and the Noelke.

[73] After the August 30, 2001 meeting, Mr Themig invoiced EOG for his expenses in a document referred to as a "field ticket." The applicable standard terms and conditions were set out on the back of the field ticket. In addition, Packers entered into a master services agreement with EOG. Neither the field ticket nor the master services agreement dealt with the issue of confidentiality.

[74] Mr Themig presented Mr Carter with a completion proposal for the Garner well on September 30, 2001. It showed an open-hole ball-drop system with RockSEAL packers. The proposal was marked "Confidential not to be disclosed outside EOG." Subsequently, around

mid-October, the proposal was modified slightly to enable the tools to be pulled out of the well after the fracturing took place.

[75] Two weeks later, on November 1, 2001, Mr Themig provided EOG with a similar completion proposal for the Noelke well. It, too, was labelled “Confidential.” The proposal was similar to the Garner plan.

[76] Most of the documents Packers supplied to EOG were stamped “Confidential.” However, speaking generally, Mr Themig conceded that a confidential label was sometimes attached to documents or drawings that were not really secret; for example, it occasionally appeared on drawings of parts that could be purchased from third parties, or on information that was already in the public domain. He agreed that the question of whether something was truly confidential sometimes required a judgment call on the part of the recipient.

[77] Mr Themig’s confidence that his disclosures to EOG would be treated as confidential derived, in part, from EOG’s designation of the Garner and Noelke wells as “tight hole.” The term “tight hole” seems to have a range of meanings. For example, Mr Lyster, of Essential, explained that “tight hole” meant that an operating company wanted information about a particular well to be kept secret; employees of service companies working on that site would refrain from discussing details with others. In the context of the Garner and Noelke wells, however, the term had a more specific meaning – it was a designation that some used to describe a policy of the Railroad Commission of Texas, which allowed mining companies to delay

reporting of certain information to the Commission. The limited significance of that designation was addressed by some of the expert witnesses whose evidence I will discuss below.

[78] In due course, after some relatively minor issues had been addressed at the wellhead, both the Garner and Noelke wells were fractured using the procedure Mr Themig had proposed. Mr Themig's previous concerns – about achieving isolation, the location of the fractures, the ability of the packers to withstand high pressures, and the ball-launching procedure – appeared to have been overcome.

[79] In roughly the same time frame, in early September 2001, Mr Themig received a phone call from Mr Al Powell, a representative of Headington Oil, in Denver, Colorado. Like EOG, Headington had heard about some of Packers' previous work using open-hole packers to achieve isolation in fracturing jobs. Mr Themig prepared proposals for Headington's Dynneson well, which were similar to the EOG proposals, and asked that they be treated as confidential. Ultimately, due to problems at the wellbore, the Headington plan had to be revised from a three-packer system down to a single fracturing segment.

[80] The pumping company at Headington, named Sanjel, produced a report showing the fluid pressures throughout the Headington job. Its report is marked "tight hole" which, according to Mr Themig, meant extremely confidential. In addition, the charts contained in the report display a watermark with the word "Confidential" on them.

[81] From Mr Themig's perspective, the three fracturing jobs in which Packers was involved in late 2001 – Garner, Noelke, and Dynneson – were all successful. Mr Themig believed that this technological development could change the industry. Packers filed its patent application on November 19, 2001. It started marketing its StackFRAC system soon thereafter, in January 2002.

[82] Mr Themig conceded that the StackFRAC system had been used prior to November 19, 2001 for EOG and Headington. However, he disagreed that Packers' method had been used publicly, given the assurances of confidentiality that he had received from both EOG and Headington. He also regarded those jobs as experiments.

C. *Experiments*

[83] In respect of experiments, to merit an exception from the general rule that prior public disclosure will invalidate a patent, Packers must prove that the disclosure was in furtherance of a real experiment (*Canadian Patent Scaffolding Co v Delgotto Enterprises Ltd* (1980), 47 CPR (2d) 77 (FCA) at para 33).

[84] In Mr Themig's view, the EOG and Headington jobs were essentially field trials. While he could not point to any documentary evidence to support his view, he maintained that if one looked at the entirety of the evidence and the circumstances of Packers' work for those customers, one would realize that the parties all regarded the running of the StackFRAC system on those sites as experimental or as a field trial, even if those words were never used. Though he described these projects as experimental, Mr Themig did not know if Packers gave EOG or Headington any kind of discount; the costing of the work was not in evidence.

[85] On the issue of experimental use, Packers relies on the expert opinion of Mr Michael Vincent. Mr Vincent stated that it is often necessary to conduct experiments at the wellsite because not everything can be tested in the laboratory. In his view, Packers' work at the Garner well represented an experiment or pilot project to test the proposed system. He based his opinion on the delays that resulted from problems running the tools into the well and setting the packers. The results showed that the experiment worked, but also that further refinements to the system were required. He also noted that EOG tried, but failed, to confirm zonal isolation through use of radioactive isotopes. In his view, that form of testing would normally have been employed only at a test site.

[86] Mr Vincent expressed a similar opinion about the Dynneson well. With respect to the Noelke well, Mr Vincent pointed out that no fracturing took place there before November 19, 2001. Therefore, there was simply no disclosure of the subject matter of the '072 patent before the relevant date.

[87] Mr Vincent also relied on the fact that the packers were inspected and repaired after the Garner job to support his opinion that Packers was conducting an experiment. However, he was unaware of the fact that EOG wanted to remove the tools from the Garner well to be repurposed at Noelke. If that was their aim, he conceded, the packers would have had to be removed, inspected, and repaired before they could be used at Noelke.

[88] On cross-examination, Mr Vincent conceded that companies conducting experiments would usually advise their clients, out of concern for the safety of their employees. In addition,

they would typically underscore the requirement of confidentiality. Further, after an experiment, someone would usually prepare a report of the results (although these reports are often confidential). There was no evidence that a report was prepared by or on behalf of Packers.

[89] Mr Michael Chambers, for the defendants, disagreed with much of Mr Vincent's opinion. He pointed out that a service company like Packers that was conducting an experiment would have specifically informed the operator, offered a discounted price, prepared a summary of the work to be conducted, tested alternative theories, ensured that a senior company representative was present on site, and prepared a detailed analysis of the results. None of those conditions were present at either the Garner or the Noelke wells.

D. *Confidentiality*

[90] Packers relies on the expert opinion of Mr Cameron Matthews who opined that oil and gas companies typically share confidential information only with persons they trust. Often, but not always, that trust is reinforced by a written confidentiality agreement. Further, many companies enact codes of conduct for their employees which require them to preserve the confidentiality of information received from suppliers and other customers, whether or not the parties have signed a written confidentiality agreement.

[91] Mr Matthews reviewed several corporate codes of conduct that he believed were in force in 2001 in the oil and gas industry, including those of EOG, Andarko, Baker Hughes, Halliburton, Schlumberger, Headington, and Sanjel. He found that they all required employees to preserve the secrecy of their company's confidential information, as well as confidential material

received from third parties. Companies find it advantageous to publish these codes, according to Mr Matthews, to assure their clients and associates that any information they share will be kept private.

[92] In addition, the Society of Petroleum Engineers (SPE) has its own code of conduct which, both today and at the relevant time, requires members not to disclose proprietary or confidential information about clients or employers without express consent.

[93] Mr Matthews found that none of the codes actually required a written confidentiality agreement to be in place in order for a duty of confidentiality to be created.

[94] In his testimony, however, Mr Matthews accepted that several of those codes of conduct do, in fact, refer to the need to enter into confidentiality agreements. Indeed, he agreed that written confidentiality agreements would be entered into in the vast majority of cases. Andarko's code, for example, says that a non-disclosure agreement may be necessary if the applicable contract does not address that issue directly. The same was true of Schlumberger's code. Mr Matthews was shown other codes of conduct – from Chevron and Spectra Energy – which referred to the need for written confidentiality agreements, and conceded that he had not reviewed those.

[95] On cross-examination, Mr Matthews also agreed that Baker Hughes' code of conduct specifically states that it is not binding on employees. Further, Mr Matthews conceded that he had found only one code of conduct that clearly was in force at the relevant time – Halliburton's.

[96] Mr Matthews also described what he viewed as the standard industry practice. Often, an oil company will want to keep secret its exploitation of a particular oilfield. It may, for example, want to preserve its ability to buy or lease surrounding land at an advantageous price; or it may wish to insulate its activities from stock market speculation. Further, it may prefer not to disclose new technologies or methods to competitors. In Mr Matthews' view, EOG was known to be an innovator in the use of multi-stage fracturing techniques and, in 2001, may have wished to keep its work confidential.

[97] The term "tight hole," according to Mr Matthews, is commonly applied to a new well site and means that "certain information cannot be disclosed about the well." This confidentiality requirement applies until it is lifted by the operating company or it expires according to local regulations. For example, in Texas, as Mr Themig mentioned in his testimony, an operator can request a "tight hole" designation, which will provide confidentiality in respect of a new well for several months. EOG made such a request in respect of the Garner well (although the term "tight hole" does not appear on the documentation).

[98] Reviewing the circumstances surrounding Packers' involvement in the Garner, Noelke and Dynneson well sites in 2001, Mr Matthews found support for Packers' claim that its disclosures were made with an understanding that they would be kept confidential. In respect of the Garner well, Mr Matthews found it noteworthy that Mr Themig had discussed confidentiality with Mr Carter and had labelled his completion proposals as confidential. Mr Matthews concluded that the overall circumstances were consistent with two companies working together on a common goal, with mutual respect and confidence in each other. Mr Matthews also

assumed that Mr Themig had prefaced his remarks to the larger group at EOG on August 30, 2001 with a request for confidentiality; as seen above, however, Mr Themig's testimony at trial did not support that assumption.

[99] On cross-examination, Mr Matthews conceded that the marking of documents as confidential would not be enough on its own to create a duty of confidentiality on the part of the recipient. One would need to look at the overall context of the relationship between the parties.

[100] Mr Matthews noted that other companies at the Garner site, including Halliburton, would have learned about Packers' ball-drop system. However, all of those parties, in his view, would have been obliged by codes of conduct and industry practices to treat that information as confidential.

[101] Similarly, based on essentially the same evidence, Mr Matthews found that the events surrounding the fracturing job at the Noelke well also supported Packers' claim of confidentiality.

[102] Further, Mr Matthews concluded that Packers and Headington had a mutual understanding about confidentiality in respect of the Dynneson well. He relied on the marking of Packers' documents as confidential, as well as Mr Themig's discussions with Mr Al Powell at Headington. In addition, the pumping company, Sanjel, and the other companies on site would have been bound by codes of conduct and industry standards to keep the information they received confidential.

[103] Packers also relies on Mr Vincent's opinion. He explained that persons working within the oil and gas industry often exchange proprietary and confidential information on the understanding that there is a duty to keep that information confidential. In his view, the Packers' completion proposals at the EOG and Headington wells would have been recognized as confidential. Therefore, in his view, there had been no public disclosure of the subject matter of the '072 patent. Further, he doubted that disclosure had been made to other services companies, particularly Halliburton and Sanjel, since they did not have representatives on site at the relevant time.

[104] The defendants rely primarily on the expert report of Mr John Ryberg. The defendants also called Ms Roseann Caldwell, Packers' patent agent, to testify about her communications with Packers prior to the filing of the patent. I found Ms Caldwell's evidence to be of no relevance to the issue of public disclosure. I have not considered it in my analysis.

[105] Mr Ryberg disputed the existence of the industry standards described by Mr Matthews. In his experience of over 23 years in the oil industry, he found that companies wishing to preserve the confidentiality of their work typically entered into written non-disclosure agreements authorized at the corporate level. Oral confidentiality agreements were not used because they were too uncertain. Further, Mr Ryberg stated that simply marking documents as confidential did not create any obligation on the part of recipients to treat them as confidential; those markings did not amount to an agreement. Rather, written agreements often specified that the parties must treat documents marked "Confidential" accordingly.

[106] Specifically, Mr Ryberg stated that there was no industry standard in 2001 that would require an operating company to preserve the confidentiality of a service company's equipment or methods. Operators wanted to gain information about what their service companies were doing in order to foster competition among those companies and drive down prices. Service companies who sold equipment to operators had no control over the operators' subsequent use of it. If a service company, such as Packers, wanted something to be kept confidential, a written agreement would be required. The same would be true for operators. If an operating company wanted to protect the confidentiality of information it was sharing with a service company, it would demand a written agreement. However, service companies sometimes voluntarily agreed to preserve the confidentiality of operators' information purely to develop good business relations with those operators. Mr Ryberg advised that there was no duty of confidentiality between service companies working on the same site.

[107] The term "tight-hole," according to Mr Ryberg, is a slang expression used in the oil and gas industry. When it is used in respect of the Texas Railroad Commission, it means that a company running an electric log on its well can request that the data be kept confidential. It does not apply to any other information, such as the equipment used or the methods employed at the well.

[108] Regarding the circumstances in this case – that is, Packers' interactions with EOG and Headington – Mr Ryberg stated that Packers had not taken sufficient steps to preserve the confidentiality of the information it disclosed on those projects. A written non-disclosure agreement signed by authorized personnel was required.

[109] On cross-examination, Mr Ryberg was asked about corporate codes of conduct, such as those referred to by Mr Matthews. In Mr Ryberg's view, those codes set out very general guidelines to be observed by employees. Asked about a 2004 version of the Schlumberger code, which was similar to the policy in place in 2001, Mr Ryberg noted that it required employees to protect confidential information "entrusted" to them. In his view, Schlumberger employees would have a duty to protect information only if it was entrusted to them pursuant to a written confidentiality agreement. Shown other codes of conduct, Mr Ryberg expressed the same opinion about them. In essence, Mr Ryberg testified that a duty of confidentiality arises pursuant to written agreements, not from codes of conduct. At best, those codes merely reinforce employees' obligations to respect the confidentiality of information that is subject to explicit non-disclosure agreements.

E. *Conclusion on Prior Disclosure*

[110] The evidence simply does not support Packers' position on prior disclosure. The early disclosures of the subject matter of the '072 patent that occurred before November 19, 2001 related neither to experiments nor to confidential communications.

[111] There is little evidentiary support for the assertion that the work Packers performed for EOG and Headington was experimental. Mr Themig testified that, to his mind, these projects were field trials. However, there is no corroboration of that perception in any of the documents the parties exchanged during the relevant time period, evidence that one would reasonably expect to find in relation to a true experiment. While Mr Themig may have believed that the system he proposed to EOG and Headington was somewhat novel, had some concerns about whether it

would work, and encountered some issues getting the equipment into the well, his subjective belief is not enough to prove that the information he disclosed was in furtherance of an actual experiment. With respect to Headington, Mr Powell testified that he regarded Packers' method as experimental, but only in the sense that it was novel and he had some concerns about whether it would work. He did not recall receiving any kind of discount.

[112] Regarding confidentiality, Mr Themig may have agreed with Mr Glenn Carter that their exchange of information on August 29, 2001 would be treated as confidential on both sides. However, Mr Themig went on the next day to disclose his ideas to a group of unknown individuals, some of whom may not have been employees of EOG. The participants were not bound by any explicit commitment to keep the discussion confidential.

[113] I am also persuaded by Mr Ryberg's testimony that standard industry practice was to commit obligations of confidentiality to written agreements. Most of the witnesses I heard confirmed that the oil and gas industry is highly competitive and that operating companies have the upper hand in dealings with service companies such as Packers. I am not satisfied that a completion engineer at EOG, Mr Carter, was in a position to commit his employer to an obligation to safeguard the confidentiality of all of the information conveyed from Packers to EOG for an indeterminate period of time. Had Packers desired that kind of umbrella protection for its proprietary information, it certainly could have sought it. There is no evidence, however, that it did so or that EOG would have agreed if asked. The fact that completion drawings provided by Packers contained a boilerplate "Confidential" label may have indicated Packers'

hope that the drawings would be treated as secret, but it does not convey any commitment on EOG's part that it would do so.

[114] The same is true in respect of the Noelke site. While the fracturing took place at Noelke after the critical date of November 19, 2001, Packers' detailed disclosure of its proposed completion method occurred well before that date.

[115] The Dynneson job for Headington involved some additional indications of confidentiality that were not present at the EOG sites. For example, Mr Al Powell, from Headington, confirmed that communications between Headington and Packers were to be considered confidential. That understanding was conveyed to the other companies on site. As mentioned, Sanjel, the pumping company, designated the site as "tight hole."

[116] To refresh Mr Powell's memory about the circumstances at the Dynneson well, counsel for Packers presented him with a written statement he had signed on April 16, 2015. The statement contained some details that he did not recall in his oral testimony; the statement also made more definitive references to confidentiality as between Headington and Packers at the relevant time. The parties agreed that the statement fell within litigation privilege. However, the defendants submitted that Packers had waived its privilege at various points when Mr Powell's forthcoming testimony was alluded to. The defendants said they should have been provided a copy of the statement well before it was presented to Mr. Powell in his oral testimony.

[117] I disagree with the defendants. There was no point when the actual content of the statement was mentioned by counsel (unlike in the case on which the defendants rely, *R v Stone*, [1990] 2 SCR 290). Further, the defendants had been provided a summary of Mr Powell's anticipated testimony which referred to the issues of experimental use and confidentiality. Mr. Powell's evidence, including the contents of his statement, should not have taken the defendants by surprise.

[118] In any case, Mr Powell made it clear that in terms of confidentiality he was mainly focussed on the secrecy of Headington's data, not the information Packers was providing. I interpret his testimony regarding confidentiality in that light. In essence, Mr. Powell was concerned about disclosure of production information at the well site because much of the land surrounding it had not yet been leased.

[119] Again, however, there is no documentary evidence to support the contention that the information conveyed by Packers to Headington or to other companies at the site was to be considered confidential. Packers' desire for confidentiality was expressed on its drawings. Mr Powell's agreement was expressed through his testimony. But there is no evidence that Packers' position was accepted by the management of Headington, that Packers' information was not disclosed to third parties, or even that Sanjel's "tight hole" designation had anything to do with Packers' disclosures.

[120] Further, I do not see any support for Packers' position in the various codes of conduct in evidence. Those codes seem merely to confirm employees' duties to respect the confidentiality

of proprietary information they may receive from their employers or third parties. But codes of conduct do not designate particular information as confidential. That designation comes about primarily through internal policies and specific agreements with outside parties.

[121] Packers contends that Halliburton was specifically bound to protect the confidentiality of Packers' disclosures because Halliburton knew that the information was designated as confidential and it had received documents labelled "Confidential". However, I have no evidence before me showing that Halliburton regarded the information it received from Packers as confidential, or that it had a specific duty to treat it that way. Packers also argues that Halliburton personnel may not have been on site when the equipment was run into the Garner well. That speculative assertion does not address the question of whether Halliburton, and others, would have otherwise been privy to the fracturing method that Packers had proposed.

[122] Finally, the disclosures Packers made to the various parties involved at the EOG and Headington sites would have enabled those persons to perform the subject matter of the '072 patent. Mr Themig described to various people how the ball-drop system worked and presented them with detailed drawings of the tools and methodology. Numerous persons were present at the well sites, observed the tools, and watched them being put to use.

[123] The preponderance of this evidence shows that there was public enabling disclosure of the invention prior to November 19, 2001, and that the disclosure related neither to an experiment nor to an exchange of information subject to a duty of confidentiality.

V. Issue 2(b) – Is the ‘072 patent invalid because the subject matter of the patent was obvious?

[124] Again, a patentee merits a monopoly only when the claimed invention is truly new, useful and unobvious. The following analysis tracks the approach to obviousness set out in *Apotex v Sanofi-Synthelabo Canada* [2008] 3 SCR 265.

[125] Packers claims that the claimed invention in the ‘072 patent was not obvious because it represented a notable advance both over the common general knowledge of skilled persons and the relevant prior art.

[126] I disagree with Packers. The claimed method of fracturing described in the ‘072 patent would have been obvious to skilled persons at the relevant time, being November 19, 2001.

A. *The Skilled Person*

[127] As mentioned, the parties essentially agree that the skilled person is a petroleum or mechanical engineer, having between two and five years’ field experience.

B. *The Common General Knowledge*

[128] Packers relies on the description of the common general knowledge of the skilled person at the relevant time provided by Dr Jennifer Miskimins. Dr Miskimins stated that the common general knowledge in May 2003 (the relevant date for construing the patent) was substantially the same as it was on November 19, 2001.

[129] Dr Miskimins states in her expert report that the skilled person would have been aware of the following aspects of oil and gas extraction:

- The variety of geological formations (*eg*, sandstone, carbonate, and shale) and their various properties (*eg*, porosity and permeability);
- The components of a typical drill site;
- Types of wells (*eg*, vertical, deviated, and horizontal);
- Casing and cementing wellbores, and running tubing strings into the well;
- The advantages of working in the open hole (versus a cased and cemented wellbore);
- Completion techniques, including the use of various kinds of packers (*eg*, cup packers, inflatables, and solid element packers (hydraulic or swellable));
- Stimulation techniques, including hydraulic fracturing;
- Fracture mechanics; and
- The economic factors that affect oil and gas production, including leasing costs, drilling expenses, and production costs.

[130] Packers also relies on the expert opinion of Mr Michael Vincent who stated that a method for achieving zonal isolation in an uncased, horizontal wellbore did not fall within the common general knowledge of skilled persons at the relevant time. Rather, the accepted wisdom was that the wellbore had to be cased and cemented.

[131] Mr Vincent agreed that the common general knowledge in 2001 included the use of solid-body packers with extrudable elements for use in open-hole wellbores, albeit not for hydraulic fracturing – only for production control, not at the high pressures required for fracturing.

[132] For their part, the defendants rely on the description of the common general knowledge set out in the expert reports of Mr Michael Chambers and Dr Vikram Rao.

[133] Mr Chambers stated that a skilled person would have known how to use two or more packers to isolate sections of a wellbore, whether cased or open-hole, in order to carry out a selective fracturing job. That person would also be familiar with different types of packers (extrudable, inflatable, mechanical, or hydraulic) that comprised more than one element, and that could withstand the pressures of open-hole fracturing. Further, according to Mr Chambers, the skilled person would have been familiar with completion techniques in both cased and open holes, including hydraulic fracturing methods using sliding sleeves activated by a ball seat device.

[134] Dr Rao emphasized the many sources of information available to the skilled person at the relevant time. Those sources included in-house training, SPE publications, and other reputable journals. He listed over 20 relevant articles that the skilled person would have had available on a reasonable search for information relating to the subject matter of the '072 patent. Dr Rao's opinion on common general knowledge covered many of the same areas as Dr Miskimins' but with additional details, including the skilled person's familiarity with:

- The use of ports with sliding sleeves activated by balls or plugs;

- Tools, including packers, that could be used either in cased or open holes;
- Packers specifically designed for use in an open hole; and
- Methods for multi-zone hydraulic fracturing in horizontal, open-hole wellbores.

[135] In her responding report, Dr Miskimins disputed some of Dr Rao's and Mr Chambers' descriptions of the common general knowledge. In particular, she disagreed with Dr Rao's contention that fracturing in an open hole within a competent formation, such as shale, was similar to fracturing in a cased hole, even within a smooth, round, solid wellbore. Further, she stated that a skilled person would not understand that solid-body packers could be used for fracturing in an open hole. He or she would be concerned that fractures would occur at the point where the packers sealed against the wellbore and would travel into the adjacent segment, thereby defeating the zonal isolation the packers were meant to achieve. Dr Miskimins also disagreed with Mr Chambers' opinion to the same effect.

[136] Further, Dr Miskimins questioned Dr Rao's opinion that certain prior art references formed part of the skilled person's common general knowledge. In fairness to Dr Rao, he clarified his opinion during cross-examination that certain papers and other information he referred to were not part of the skilled person's common general knowledge, but they were part of the relevant prior art, easily discoverable by persons researching the field of the invention. I will describe these sources in the next section.

[137] In his reply to Dr Miskimins' and Mr Vincent's opinions, Dr Rao disagreed with the view that skilled persons in 2001 would have believed it necessary to case and cement a wellbore

before fracturing. Dr Rao stated that the skilled person would be familiar with formations that could be fractured without casing and cementing the wellbores. While casing and cementing increases certainty about the success of a fracturing job, it also greatly increases the cost. In Dr Rao's view, the skilled person would be aware of that trade-off.

[138] Finally, Dr Rao disagreed that skilled persons would have the concerns identified by Dr Miskimins and Mr Vincent about fracturing in an open hole – that is, creating longitudinal fractures, fracturing at the point of contact between the packer and the wellbore, the inability to fracture at a precise location, and fracturing around the packer, resulting in a loss of zonal isolation. Dr Rao maintained that creating longitudinal fractures is an issue both in cased and open-hole wellbores. In addition, the skilled person would know which types of packers to use in order to minimize the risk that a fracture would occur where the packer met the wellbore. Dr Rao agreed that use of perforated casing allows for greater precision in targeting the best fracturing point but, typically, the best place to fracture will actually be unknown in advance. He also noted that nothing in the claims in issue (except claim 102) states that perforation could not be carried out. If precision is desired, the skilled worker would realize that it might be necessary to perforate the wellbore. Generally, Dr Rao found the concerns cited by the other experts to be theoretical, not practical, and observable only in laboratories, not in the field.

[139] While the gap between these disparate descriptions of the common general knowledge may appear to be wide, their significance diminishes when one considers the state of the actual art at the relevant time.

C. *The Inventive Concept and the State of the Art*

[140] The heart of the analysis of obviousness involves a comparison between the inventive concept of the patent and the state of the art at the time. The parties produced substantial expert evidence on this question, which I summarize below. On balance, I am satisfied that the evidence supports the defendants' position that the inventive concept of the '072 patent did not represent an advance over the state of the art.

[141] For Packers, Dr Miskimins described the inventive concept of the claims in issue as being integrally tied to the sequential fracturing of an open-hole wellbore.

[142] Similarly, Mr Vincent described the inventive concept of the patent as being a method to effectively fracture an open-hole wellbore with a ball-drop system permitting sequential fractures. The most important aspect of the inventive concept, in his view, was the use of the ball-drop method in an open-hole.

[143] On cross-examination, Mr Vincent elaborated on his understanding of the inventive concept of the patent. He pointed to the "elegant solution" laid out in the patent, which involved fracturing between paired packers attached to a tubing string. That arrangement, in Mr Vincent's opinion, solved a problem frequently encountered in the field: packers blowing out when exposed to high-pressure fluid injection. The patent discloses a solution to that problem: offsetting the reciprocal pressures forcing one packer uphole and another downhole. Mr Vincent conceded that while this potentially inventive aspect of the ball-drop method was not explicitly mentioned in the patent (or even in his own report), a skilled person reading the patent would

recognize it. He also agreed that this solution was previously disclosed in prior art and that there was nothing new about it in 2001.

[144] For the defendants, Mr Chambers had difficulty identifying an inventive concept of claims 96-111 of the '072 patent. In his view, the claims describe a ball-drop system for fracturing an open-hole section of a wellbore. A skilled person, according to Mr Chambers, would not regard that method as inventive. Even if the inventive idea was to apply a previously known technology, the ball-drop system, to a new environment, the open hole, the patent does not mention that step or provide any information about how to make it. A skilled reader of the '072 patent, Mr Chambers says, would have assumed that the cased-hole method described in the prior art could easily be adapted to the open hole, provided that the wellbore was sufficiently competent to accommodate it.

[145] Dr Rao, another of the defendants' experts, concluded that the inventive concept of the relevant claims of the '072 patent is a method for isolating and selectively fracturing individual zones of a wellbore. Essentially, this concept equates with the ball-drop system, which he described as "clever." In his view, a potentially novel feature of the system was the use of different-sized balls and ball seats to permit sequential fracturing of different zones. However, in his view, the use of this system in an open-hole wellbore did not form part of the inventive concept given that the patent itself states that the system could be used in either a cased wellbore or an open hole, and provides no information to skilled readers about any differences or difficulties that might be encountered in the two settings. Further, as Dr Rao points out, a skilled

reader would know that the packers suitable for a cased hole would differ from those for an open hole, but the patent provides no teaching on that subject.

[146] Dr Rao specifically disagreed with Dr Miskimins' opinion that the inventive concept of the '072 patent related to the use of the ball-drop system in the open hole. In any case, according to Dr Rao, the open-hole setting simply required a skilled person to implement a known method using an appropriate open-hole packer. That person, in his view, could easily make that choice based on the common general knowledge at the time, and without any inventive step.

[147] I accept Packers' submission that the inventive concept of the relevant claims of the patent is the use of the ball-drop method in an open-hole wellbore. The claims repeatedly refer to the open-hole setting. While the patent may not describe the operation of the claimed method in the open hole, that is a question of sufficiency of disclosure unrelated to the inventive concept.

[148] The real question, however, is whether there is a difference between the inventive concept and the state of the art at the time. Again, there was significant expert testimony on this question.

[149] For Packers, Mr Vincent concluded that the invention described in the '072 patent was not obvious when compared to the common general knowledge of the skilled person. In 2003 or so, when he first learned of the method proposed in the patent, he did not believe it would work and advised his clients not to use it. The conventional wisdom at the time was that it was essential to case and cement the wellbore before attempting to fracture it. Mr Vincent cited a

number of publications supporting that view. Further, he pointed out that operators typically fractured within lengthy zones of the wellbore, not comparatively short segments as envisioned by the claimed method. Still, in his view, not only does the patented method work, it has become highly successful commercially and well-recognized in the industry.

[150] The defendants rightly point out that Mr Vincent compared the inventive concept with the common general knowledge of the skilled person, not with the state of the art. With respect to the prior art publications on which the defendants rely to describe the state of the art, Mr Vincent concluded that the skilled person would not have located those publications on a reasonably diligent search. I discuss this aspect of his testimony below.

[151] For the defendants, based on his conclusion that the sole inventive concept was the ball-drop system, Dr Rao testified that there was no difference between that concept and the state of the art at the time. He found that the state of the art was reflected in the following:

- Two publications by Albert Yost in the late 1980s. Yost described his experiments with fracturing techniques, including zonal isolation achieved by inflatable packers and ports opened by sliding sleeves, in open-hole horizontal wellbores;
- A paper published by Bill Ellsworth (and Mr Themig) in 1999, describing the use of solid-body packers and sliding sleeves to achieve zonal isolation in a horizontal, open-hole wellbore; and

- Three publications authored by Thomson in 1997-1998, in which he described a method for fracturing a horizontal, cased wellbore in multiple stages, by using solid-body packers and a ball-drop system.

[152] In essence, Dr Rao found no difference between the inventive concept of the '072 patent and Thomson's earlier work; Thomson described in his papers a ball-drop system indistinguishable, according to Dr Rao, from the method claimed in the '072 patent. Therefore, the subject matter of the '072 patent was obvious when compared to the state of the art.

[153] I have reviewed these primary prior art publications. As I read them, they show that the subject matter of the claims in issue did not represent an inventive step over the state of the art, even accepting Packers' version of the inventive concept (the ball-drop system in an open hole).

[154] The main Yost paper (SPE 19090), published in 1989 and presented at an SPE symposium in Dallas, Texas, was entitled "Production and Stimulation Analysis of Multiple Hydraulic Fracturing of a 2,000-ft Horizontal Well." It describes multiple fracturing treatments in a horizontal open-hole wellbore in Devonian shale in West Virginia. Yost notes the disadvantages of fracturing in perforated, lined wellbores – there is a risk of having to pull the liner and re-run another casing string for selective fracturing. He preferred an alternative approach – zonal isolation using inflatable packers in the open hole. That approach would avoid formation damage and obviate the need to perforate the wellbore. The method Yost described involved 8 packers and 14 sliding sleeve ported collars, creating 7 open-hole zones (one packer

failed). He concluded that the packers achieved zonal isolation, the wellbore was stimulated, and production increased.

[155] Yost's approach shows the use of inflatable packers in an open hole in order to achieve zonal isolation for purposes of selective stimulation of discrete segments of the wellbore.

However, it did not include the use of solid-body packers, or sliding sleeves activated by a ball-drop system.

[156] The Ellsworth publication (1999), co-authored by Mr Themig, was entitled "Production Control of Horizontal Wells in a Carbonite Reef Structure." It described work conducted in Rainbow Lake, Alberta that involved the use of solid-body packers for purposes of isolating segments of an open-hole wellbore. The paper begins with a statement that "[o]pen-hole completions have been the accepted practice for horizontal wells in the Rainbow Lake area of Northern Alberta." It notes recent advancements in achieving isolation in open-hole completions for various purposes, such as isolating water or gas from the oil-producing wellbore. It touts the advantages of hydraulically-set solid-body packers (such as the Wizard packer, designed by Mr Themig) over inflatables as they "provide a long-term solution to open hole isolation without the aid of cemented liners." The paper describes four illustrative case histories which showed the effectiveness of the packers in achieving isolation and the use of sliding sleeves within the zones. In summary, the paper notes that "[t]he ability to establish long-term zonal isolation in open hole producers opens the door to many new well producing configurations." Further, "[t]he goal of cost effective use of horizontals can be enhanced with the ability to segment, and control production without the need to run and cement liners".

[157] The Ellsworth paper shows the value of solid-body packers in the open hole and the use of sliding sleeves between the packers. It did not deal with fracturing directly, but alludes to the wide variety of potential uses to which these packers might be put which, given the context, would include zonal isolation for fracturing purposes. As Dr Rao pointed out, the Ellsworth paper actually includes a description of the successful use of solid-body packers to isolate zones of an open-hole wellbore for purposes of stimulating the formation.

[158] The Thomson paper, from 1997, describes the ball-drop system, albeit in a cased wellbore, used in the fracturing of an area of the UK North Sea, southeast of Aberdeen, Scotland. The paper is entitled “Design and Installation of a Cost Effective Completion System for Horizontal Chalk Wells Where Multiple Zones Require Acid Stimulation.” The authors describe the system they employed as “innovative” but not novel – the design was based on earlier work done by the Phillips Petroleum Company in which a multi-stage acid frac tool (MSAF) had been developed. No date is provided for the earlier work. The method described in the Thomson paper involved multiple fracturing zones, the MSAF, sliding sleeves, hydraulically-set retrievable packers, threaded ball seats, and progressively-sized balls. The authors found the method to be “highly efficient”, allowing fracturing of 10 zones in 12-18 hours, with significant cost savings. Further, efficiencies resulted from the ability to treat each segment of the horizontal well appropriately – the treatment could be matched with the conditions in each segment.

[159] The parties dispute whether these prior art references would have been located by a skilled person in a reasonably diligent search.

[160] For Packers, Mr Vincent took the approach that the skilled person would have looked for prior art that addressed the problems that EOG was having at the Garner well. EOG was looking to use resettable packers in an effort to stimulate a dual lateral open-hole wellbore to boost production of hydrocarbons. EOG said that “[a]dequately and properly stimulating each lateral, economically, is a big challenge.” In addition, EOG told Mr Themig that it was “very interested in your resettable open hole packers to perform numerous smaller treatments in each lateral, which would allow us to accomplish our stimulation objectives.” Mr Vincent inferred that EOG wanted to stimulate one branch of the wellbore and then move the packers to the other. His view was that a skilled person looking for guidance in the literature to address that problem would not have come upon the prior art publications described above because that person would have been looking for publications on dual or multilateral wells. Accordingly, he disputed Mr Chambers’ description of a reasonably diligent search based Mr Chambers’ failure to consider search terms such as “dual lateral” or “multilateral”.

[161] More particularly, Mr Vincent did not believe the skilled person would have located Yost’s work. He did not become aware of the Yost paper until 2003. He believed a skilled person would not have been aware of it in 2001, so it could not have been generally accepted in the field of the invention. In addition, looking at the data Yost generated, Mr Vincent concluded that Yost’s method failed to achieve zonal isolation, contrary to Mr Chambers’ and Dr Rao’s opinions. Yost noted that some of the fluid injected in one zone found its way into another. He concluded that, rather than a failure to achieve zonal isolation, the data showed that there were natural fractures in the formation that allowed the fluid to migrate from one zone to another. Mr

Vincent attributed the data to a failure to achieve zonal isolation, or a failure of the packers to provide a proper seal between zones.

[162] Regarding Ellsworth, Mr Vincent characterized the paper as relating solely to production control, not fracturing, and believed that a skilled person would not have located it when looking for sources to assist with the EOG fractures. Therefore, the paper would not have described a method representing a generally accepted approach to fracturing in 2001.

[163] Finally, in respect of the Thomson paper, Mr Vincent opined that it, too, was not generally accepted by skilled persons in the industry in 2001. After publication of that paper, the method described in it was not used anywhere else, even by Thomson's employer, Halliburton (the fracturing company at the EOG wells), either in a cased or an open hole. Thomson did not raise the possibility of using the ball-drop system in an open hole; rather, he emphasized the importance of using a cased and cemented wellbore.

[164] Overall, Mr Vincent concluded that a skilled person, even if he or she had found these publications, could not arrive at the invention of the '072 patent without some degree of inventiveness.

[165] I have two reservations about Mr Vincent's testimony in this area. First, I do not believe he characterized the EOG fax to Mr Themig fairly. The fax specifically mentioned the use of open-hole packers to stimulate multiple segments of each lateral. Even if a skilled person had relied on this fax to define the scope of a search for prior art, as opposed to searching the general

field of the invention, he or she would have been looking for information on techniques for conducting multiple sequential fractures suitable for use in a horizontal open-hole wellbore. The fact that the technique would be employed in a dual lateral well was irrelevant.

[166] Second, Mr Vincent evaluated the prior art publications mainly to determine whether they formed part of the skilled person's general knowledge; he downplayed their significance as prior art.

[167] On the defendants' side, the experts were presented with a list of references, including the papers I described above, and were asked to provide their opinion on whether those papers would have been located by a skilled person on a reasonably diligent search in 2001. Dr Rao and Dr Chambers both said yes.

[168] Dr Rao disputed Dr Miskimins' and Mr Vincent's conclusions that the skilled person would not have located the references on which Dr Rao had relied, including the Yost, Ellsworth, and Thomson publications. In his view, those papers relate to the field of the invention described in the '072 patent – selective communication to a wellbore for fluid treatment – and would have been located on a reasonably diligent search. In respect of the Yost paper in particular, Dr Rao testified that it had been widely disseminated by the US Department of Energy and cited by some as representing a breakthrough in the industry.

[169] The defendants contend that all publicly available prior art should be considered in the obviousness analysis, not just art that a skilled person would turn up on a reasonably diligent

search. They cite: *Mylan Pharmaceuticals ULC v Eli Lilly Canada Inc*, 2016 FCA 119 at para 23-25, 29, and *Pollard Banknote Limited v BABN Technologies Corp*, 2016 FC 883 at para 194-195.

[170] In this case, it is unnecessary to address this question as I am satisfied that the prior art described above would have been located by a skilled person conducting a reasonably diligent search.

[171] Another source cited both by Mr Chambers and Dr Rao was a US patent issued to Stephen Carlisle, *et al.* Dr Rao believed that the Carlisle patent disclosed the invention in the '072 patent. Mr Vincent disagreed. He accepted that the Carlisle patent described the potential use of a Wizard packer in the stimulation of a wellbore, but pointed out that the Carlisle patent actually addresses another method for fracturing involving the use of cup packers.

[172] Having reviewed the Carlisle patent, I find that it does not actually disclose the invention of the '072 patent. However, it includes an important reference to the state of the art at the relevant time.

[173] The Carlisle US Patent 6,315,041 was filed on April 15, 1999, and issued on November 13, 2001. The patent is entitled "Multi-zone Isolation Tool and Method of Stimulation and Testing a Subterranean Well." Under the heading "Field of the Invention," the following appears:

The invention relates generally to the field of oil and gas well stimulation, and more particularly, to isolating segments of a subterranean cased or open hole well for stimulating and/or testing purposes.

...

There is another tool, the Wizard Packer from Dresser, that allows isolation of a horizontal well into preset lengths to facilitate stimulation of the formation, but it requires sending darts into the sections to open sliding sleeves which allow the treatment fluid to enter into the isolated section. Despite the isolation, there is sometimes still no stimulation within the preset segment if one or more of the interval sections does not contain a natural fracture to enhance. There is no way to adjust the isolated length and effectively stimulate a new length without removing and resetting the entire system. The Wizard Packer is often prohibitively expensive, and is not retrievable. The Wizard Packer is fairly long in length and rigid, such that it often cannot negotiate small radius turns in a wellbore. There is a need for a less expensive, more maneuverable tool to isolate sections of the horizontal lateral at any length without removing the tool from the wellbore since the time and expense for each entry and withdrawal of a tool from a well is significant.

[174] I interpret this passage as describing the state of the art in 1999. It summarizes the ball-drop system using solid-body packers to isolate segments of the wellbore for purposes of stimulating those segments, and makes no mention of that method being confined to a cased and cemented wellbore. It describes the shortcomings of Wizard packers – expense and manoeuvrability – but does not suggest that those tools had not been used successfully to achieve zonal isolation for stimulating open-hole wellbores.

[175] In fact, the brochure describing the Wizard packer (published by Dresser Oil Tools prior to November 19, 2001), claimed that the packer represented “. . . a revolutionary approach to providing rock solid isolation in horizontal wells.” Further:

The Wizard Packer is an isolation packer designed to be run and set in open hole or cased hole. Wizard Packers can be run and set in tandem to isolate individual sections within a well.

...

The Wizard isolation system contains elastomers with high expansion ratios to conform to openhole irregularities.

[176] The brochure lists various applications for the packer, including:

- Water shut-off
- Gas shut-off
- Stimulation
- Production testing
- Formation fracture isolation
- Selective production
- Individual interval stimulation and clean-up
- Stage cementing jobs
- Horizontal

[177] The brochure confirms the reference in the Carlisle patent to the state of the art well before the filing of the '072 patent. The art included the use of solid-body packers to achieve zonal isolation for purposes of stimulating and fracturing horizontal open-hole wellbores.

[178] In an effort to show that the prior art would have been located by a skilled person at the relevant time, the defendants called Ms Rebekah Stacha from the SPE to give evidence about how the SPE database could have been searched. She testified that in 2001 the SPE's eLibrary permitted full-text searches of the first page of each publication.

[179] Ms Stacha also referred to an Instruction Manual that explained how the SPE's resources could be searched. I agree with Packers that this document is inadmissible as a business record; I had no evidence before me about who prepared the Manual, or under what circumstances.

However, I accept Ms Stacha's oral testimony, based on her personal knowledge, about how the SPE's publications could have been searched in 2001.

[180] I note that the Yost paper would have been located if any of the following terms had been searched:

- Production
- Stimulation
- Multiple
- Hydraulic
- Fracturing
- Treatments
- Zone isolation
- External casing packers
- Port collars
- Open hole

[181] Similarly, one would have located the Ellsworth paper by searching for:

- Open hole completions
- Horizontal
- Production control
- Isolation

[182] Finally, a skilled person would have located Thomson by searching for:

- Completion
- Multiple
- Horizontal
- Stimulation
- Efficient
- Zones
- Single trip
- Multi-stage
- Sliding sleeve
- Isolation
- Hydraulic-set packers
- Ball seat
- Separate
- Targeted

[183] On discovery, Packers admitted that the Thomson paper would have been located by a skilled person conducting a diligent search. However, Packers later qualified its admission, which it characterizes as a correction to an answer on discovery. Packers says that the issues narrowed as the trial approached and it was entitled to clarify its previous admission. At this point, little turns on this disagreement as I am satisfied that the Thomson paper would have been located when searching for prior art in the field of the invention.

[184] In my view, a skilled person interested in the subject matter of the invention at the relevant time would have located the Yost, Ellsworth, and Thomson publications using the potential search terms set out above. These publications, along with the common general knowledge of the skilled person, constitute the corpus of citable art for purposes of the obviousness analysis.

[185] The question, then, is whether the inventive concept of the '072 patent represented an advance over that prior art. In my view, it did not.

[186] Packers does not claim any inventiveness in the ball-drop method. Clearly, that formed part of the prior art (Thomson). The only remaining question is whether use of the ball-drop system in the open hole was inventive. Again, in my view, no.

[187] As Packers concedes, the prior art disclosed packers suitable for withstanding fracturing pressures in an open hole, as well as the benefits of completing open holes as compared to casing and cementing the wellbore. The skilled person would have known which packers would be suitable for open-hole fracturing.

[188] Indeed, both EOG and Headington came to Packers to explore the use of Packers' open-hole packers for stimulating wellbores in segments. Packers' clients may have seen, or heard about, the use of those packers for fracturing. In fact, Mr Powell testified that he heard about a Calgary company (Packers) that had equipment for use in the open hole for isolating and fracturing segments of a wellbore. Packers simply added a non-inventive feature – the ball-drop

system – to the method already envisioned by EOG and Headington and, more importantly, disclosed in the prior art.

[189] There is no evidence before me about how Mr Themig came up with the ball-drop system in his proposals to EOG and Headington. He says he had no knowledge of Thomson's work at the time (although he became aware of it later), even though he and Thomson were both employees of Halliburton when Thomson carried out his work. He certainly never presented it to EOG or Headington as a novel idea. As discussed, he did not assiduously assert confidentiality in his proposals. Ultimately, of course, he became aware of Thomson's work as it was included in the prior art presented to the patent office.

[190] Mr Themig distinguished the methodology described in the Thomson paper from the '072 system on the basis that the former involved fracturing in a cemented, cased, and perforated wellbore, and the latter relates to fracturing in an open hole. The Thomson procedure, according to Mr Themig, is much more complicated and costly than the '072 method.

[191] The experts agree that there were economic advantages to fracturing in the open hole, assuming that the formation was sufficiently competent, and there would have been a motivation to employ a method for doing so. The packers available and known to skilled persons at the time were capable of creating seals under high pressure in open-hole environments. If the formation was not sufficiently competent, the skilled person would realize that the wellbore might have to be cased and cemented, and would choose the appropriate tools for doing so. Again, that person

would know the features of the formation in which the fracturing was to occur and would choose the appropriate tools; the patent provides no guidance on that subject.

[192] Packers places heavy reliance on the problems that a skilled person would have foreseen with respect to using the ball-drop system in the open hole to suggest that the invention was not obvious. As mentioned above, these included creating longitudinal fractures, fracturing at the point of contact between the packer and the wellbore, the inability to fracture at a precise location, and fracturing around the packer, resulting in a loss of zonal isolation. Some of these potential issues a skilled person could address in various ways – by choosing the appropriate packer, setting it at the right pressure, and possibly perforating the wellbore. I did not hear evidence about what the conditions were at the Garner, Noelke, and Dynneson wells, but presumably Mr Themig learned that the geology of those formations had the necessary characteristics to permit open-hole fracturing. The likelihood of success was a function of the formation, not the methodology.

[193] Sometimes, commercial success can be an indicator of inventiveness. I have no direct evidence before me about Packers' commercial success in marketing its tools. I did, however, hear evidence about the awards Packers, Mr Themig, and his colleagues have received over recent years for entrepreneurship, awards that I am sure were well-deserved. That evidence, however, does not advance Packers' claim of inventiveness.

[194] Packers asks the question “if the invention was obvious, why did no one else come up with it?” (the so-called *Beloit* question). The evidence shows that others did come up with the

ball-drop system and did use solid-body packers to achieve zonal isolation in an open-hole wellbore. But, as I have suggested, the critical factor for the success of the patented method was neither the design nor the components; it was the quality of the wellbore into which it was introduced. As it turned out, the ideal formation is shale. With the rise of prices for oil and gas in the 2000s, interest grew in fracturing shale and the method described in the '072 patent was used with great success. It was only then that Packers and other companies marketing similar technologies realized significant commercial successes.

[195] On my review of the whole of the evidence on this question, the inventive concept of the '072 patent – use of the ball-drop method in the open hole – did not represent an advance over the state of the art at the time.

D. *Was the Invention Obvious to Try?*

[196] In a field “where advances are often won by experimentation” (*Sanofi*, above, at para 68) it may be appropriate to consider whether the invention was obvious to try. I highly doubt that the oil and gas industry could be characterized this way. Numerous witnesses confirmed that the industry is typically reluctant to try new techniques because failures can be extremely costly.

[197] Nevertheless, the factors relevant to an obvious-to-try analysis reinforce my conclusion that the claimed invention was obvious.

[198] First, was it more or less self-evident that what was tried ought to have worked? In my view, yes. The ball-drop system had been shown to work by Thomson, and it was otherwise

known in the prior art (Carlisle). Packers that could sustain fracturing pressures and temperatures in the open hole were known. Skilled persons would have expected that that combination of components would achieve the desired result. It would have been more or less self-evident that the patented method would work, so long as the characteristics of the wellbore were suitable.

[199] What was the extent, nature, and amount of effort required to achieve the invention? The evidence shows that Mr Themig arrived at the method he proposed to EOG quite readily. He sketched it out (along with other potential approaches) en route to his meeting with Mr Glenn Carter. After the meeting, Mr Themig returned to Calgary and set about designing, building, and testing the components of the ball-drop system. The entire process between conception and implementation amounted to no more than several weeks.

[200] Was there a motive provided in the prior art to find the solution the patent addresses? Thomson's work showed the advantages of the ball-drop system in terms of time saved, efficiency, and efficacy. Skilled workers, knowing the additional advantages of fracturing in the open hole – avoiding the cost and time spent casing and cementing the wellbore – would have been motivated to employ the ball-drop system in an uncased and uncemented wellbore, so long as the wellbore was suitable.

E. *Conclusion on Obviousness*

[201] The relevant claims of the '072 patent did not constitute an advance over the state of the art at the time. The ball-drop system combined with packers suitable for use in the open hole was known in the prior art, or was an obvious variation on prior art methods.

VI. Issue 2(c) – Is the ‘072 patent invalid because the patent’s claims lack utility?

[202] A patentee merits a monopoly only when the claimed invention is truly new, useful and unobvious.

[203] The defendants submit that the stated utility of the ‘072 patent – selective communication of fluids to isolated segments of the wellbore – had not been demonstrated as of the filing date of the patent. They also argue that the utility of the claims could not have been soundly predicted at that point.

[204] To begin with, the defendants present a technical assault on the drafting of the claims in issue, based on the concept of “claim differentiation.” Claim 97 claims the method described in detail in claim 96 but specifies that the sliding sleeves must be closed. The remainder of the claims, Claim 96 and the dependant claims 98 to 111, do not specify that the sleeves must be closed. Therefore, those claims, according to the defendants, must be read as covering both open and closed sleeves and, since the method works only if the tubing string is run into the wellbore with the sleeves open, claims 96 and 98 to 111 describe a method that will not work.

[205] I do not agree with the defendants’ construction of the claims. Any skilled reader of the patent would understand that the claimed method would work only if the sleeves were closed; otherwise, it would be impossible to pressure up the tubing string and set the packers. However, it would be possible to run the tubing string into the wellbore with the sleeves open and then close them by some mechanical means before pumping fluid. Accordingly, a skilled reader

would interpret claims 96 and 98 to 111 as covering the running of the tubing string with the sleeves either open or closed but, in the former case, a means of closing the sleeves would be required. Claim 97 simply covers the closed-sleeve scenario specifically.

[206] Packers disputes the defendants' overall position on utility and claims that its patented method was useful because its utility had been demonstrated or, at least, could be soundly predicted at the relevant date. I am not satisfied that the evidence shows that the utility had been demonstrated, but I agree with Packers on sound prediction.

[207] Mr Vincent testified that Packers had demonstrated the utility of the claimed invention at the Garner well. The information gathered at the well site showed that gas production increased significantly after fracturing. Mr Vincent interpreted that data as showing that the packers succeeded in distributing the fracturing fluids in a more beneficial manner. In addition, he stated that the information from the Dynneson well, particularly pressure data, showed that the packers had achieved zonal isolation.

[208] On the other hand, Mr Vincent very pointedly testified that evidence of increased production with respect to Yost's project did not necessarily prove that Yost had achieved zonal isolation. His evidence on this point seemed contradictory. Further, while the data on the Dynneson job may have shown zonal isolation, the patented method was not used on that site. No other direct evidence supporting a conclusion that zonal isolation had been achieved was presented. Finally, the patented method was tried only with Packers' RockSeal tools, not with any other solid-body packers. Since the patented method does not require any particular type of

solid-body packer, there is no evidence showing that utility across the breadth of the claims had actually been demonstrated.

[209] With respect to sound prediction, Packers must show that there was a factual basis for a prediction that the claimed method would work, a sound line of reasoning to support that prediction, and disclosure in the patent of both the factual basis and line of reasoning (unless they arise from the common general knowledge of the skilled person).

[210] Packers points to the completion proposal included in the patent (Figure 1A) as evidence that the patent disclosed a factual basis for a sound prediction of utility. In an interesting inversion of logic, Packers points to Mr Chambers' opinion, set out above, that the work on the Garner well disclosed the claimed invention before the patent was filed to argue that, therefore, the patent's description of the claimed method must be referring to the Garner job. I do not agree. The fact that the subject matter of the patent was disclosed before the patent was filed cannot, in itself, support an inference that the patent sets out a factual basis for a sound prediction of utility.

[211] I agree with Dr Rao's opinion on this issue. Dr Rao opined that there was no factual basis in the patent supporting a sound prediction that the ball-drop system would achieve zonal isolation in the open-hole with all solid-body packers. Still, he conceded that a skilled person would recognize that the claimed method would work so long as an appropriate solid-body packer was chosen, and that that choice could be made by a skilled person. While Mr Themig's testimony was that he did not really know if packers other than the RockSeal would work,

several experts testified that the choice of an appropriate packer was within the expertise of the skilled person.

[212] Obviously, choosing the appropriate packer would be a key factor in terms of the skilled person's ability to predict that the claimed method would work. Even more important, though, would be the skilled person's recognition that the patented method would not work in all open-hole wellbores. It would be likely to work only in those that replicated to some degree the characteristics of a cased and cemented wellbore.

[213] Accordingly, I am satisfied that the utility of the relevant claims of the '072 patent was soundly predictable at the date of filing because the factual basis and line of reasoning would have been within the knowledge of a skilled person, and sufficient information was included in the patent to permit the skilled person to arrive at that conclusion. This finding is consistent with my conclusion above that the claimed invention was obvious in light of the state of the art.

VII. Issue 2(d) – Is the '072 patent invalid because the specification of the patent was deficient?

[214] Finally, the defendants maintain that the '072 patent does not comply with the requirement to describe how the invention works (s 27(3), *Patent Act* (see Annex B for statutory references)). They allege that Mr. Theming deliberately left details out about the tools and methodology required to work the patent in order to maintain a market advantage, an objective inconsistent with an inventor's obligation to disclose his or her discovery to the public in exchange for a monopoly.

[215] I disagree with the defendants. The patent's description of the invention is adequate. A skilled person would be able to make use of the invention relying solely on the patent's specification (*Teva Canada Ltd. v. Pfizer Canada Inc.*, 2012 SCC 60 at para 50).

[216] In particular, the defendants submit that the patent does not specify the solid-body packers that should be used or the ball-seat clearances that would be required. However, the patent does define what a solid-body packer is and makes reference to the desirability of using packers with multiple packing elements. The skilled person would understand that certain hydraulically-set packers were available on the market, and would be aware that some of them had features, such as anti-presets, that would make them particularly suitable. Further, a skilled person, an experienced engineer, would be capable of calculating the ball-seat clearances that would be required to employ the patented method. I note that none of the experts had any real difficulty understanding the invention described in the patent.

[217] The defendants also made reference to the requirement to set out the "best mode" for working the invention (s 27(3)(c), *Patent Act*). However, that requirement relates only to machines. Here, the patent relates to a method. Certainly, that method involves the use of components and tools that could collectively be referred to as machinery. But that does not render the invention a machine. In my view, the "best mode" obligation does not apply here.

Therefore, the patent's specification was not deficient.

VIII. Conclusion and Disposition

[218] In my view, Packers has not established that Essential infringed the '072 patent either directly or in concert with others. Further, the evidence does not support Packers' claim that Essential induced others to infringe the patent.

[219] In addition, I find the defendants have proved that the patent is invalid because the invention was previously disclosed, and for obviousness. The defendants have not established, however, that the patent is invalid for inutility or deficient disclosure.

[220] Therefore, I must dismiss Packers' claim of infringement and grant the defendants' counterclaim of invalidity.

JUDGMENT IN T-1741-13, T-1569-15, T-1728-15 AND T-2088-15

THIS COURT'S JUDGMENT is that:

1. The plaintiffs' claim of infringement against Essential is dismissed, with costs;
2. The defendants' counterclaim of invalidity is granted, with costs.

"James W. O'Reilly"

Judge

ANNEX "A"

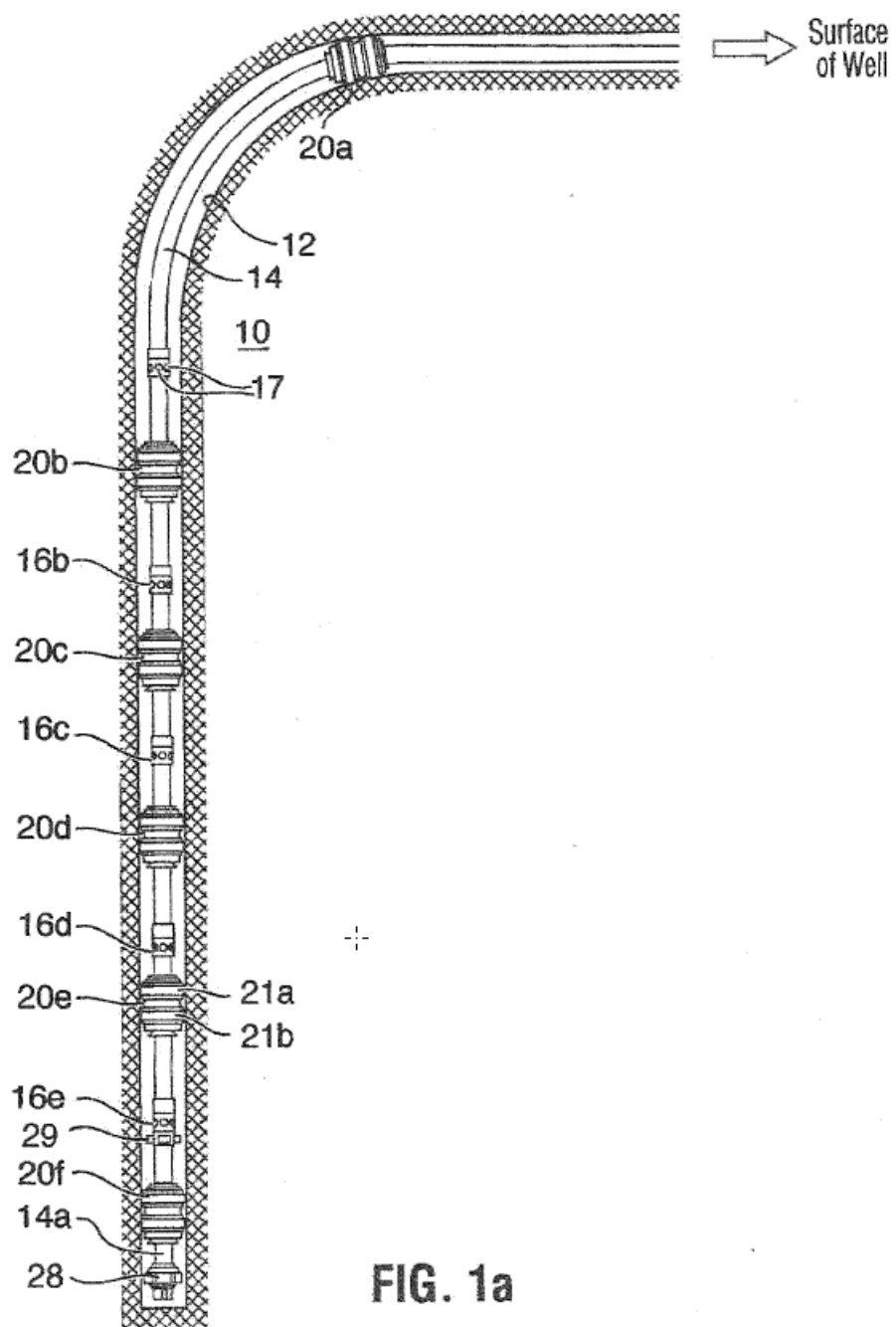

Annex "B"

*Patent Act (RSC 1985, c P-4)**Loi sur les brevets (LRC (1985), ch P-4)*

27. (3) The specification of an invention must

(a) correctly and fully describe the invention and its operation or use as contemplated by the inventor;

(b) set out clearly the various steps in a process, or the method of constructing, making, compounding or using a machine, manufacture or composition of matter, in such full, clear, concise and exact terms as to enable any person skilled in the art or science to which it pertains, or with which it is most closely connected, to make, construct, compound or use it;

(c) in the case of a machine, explain the principle of the machine and the best mode in which the inventor has contemplated the application of that principle; and

(d) in the case of a process, explain the necessary sequence, if any, of the various steps, so as to distinguish the invention from other inventions.

27. (3) Le mémoire descriptif doit :

a) décrire d'une façon exacte et complète l'invention et son application ou exploitation, telles que les a conçues son inventeur;

b) exposer clairement les diverses phases d'un procédé, ou le mode de construction, de confection, de composition ou d'utilisation d'une machine, d'un objet manufacturé ou d'un composé de matières, dans des termes complets, clairs, concis et exacts qui permettent à toute personne versée dans l'art ou la science dont relève l'invention, ou dans l'art ou la science qui s'en rapproche le plus, de confectionner, construire, composer ou utiliser l'invention;

c) s'il s'agit d'une machine, en expliquer clairement le principe et la meilleure manière dont son inventeur en a conçu l'application;

d) s'il s'agit d'un procédé, expliquer la suite nécessaire, le cas échéant, des diverses phases du procédé, de façon à distinguer l'invention en cause d'autres inventions.

ANNEX “C”

Expert Profiles

Mr Michael Roy Chambers Sr.: Mr. Chambers holds a Bachelor of Science degree in Petroleum Engineering from the Texas A&M University. He has over 35 years of experience as an engineer, manager and consultant in the oil and gas industry. Mr. Chambers has authored over a dozen publications and has given numerous industry presentations. He holds four patents in the United States related to oil and gas technology.

Dr Jennifer Miskimins: Dr. Miskimins is an Associate Professor at the Colorado School of Mines with over 15 years of teaching experience. She holds a Bachelor of Science degree in Petroleum Engineering from the Montana College of Mineral Science and Technology. She also holds a Master of Science degree and a Ph.D. in Petroleum Engineering from the Colorado School of Mines. Dr. Miskimins is a registered Professional Engineer in the State of Colorado. In addition to her academic experience, Dr. Miskimins was a Senior Consulting Engineer at Barree & Associates between 2013 and 2016.

Dr Vikram Rao: Dr. Rao is the Executive Director of the Research Triangle Energy Consortium. He holds a Bachelor of Technology degree in Metallurgy from the Indian Institute of Technology. He also holds a Master of Science degree and a Ph.D. in Materials Science and Engineering from Stanford University. Dr. Rao has authored numerous articles and books for the oil and gas industry. He owns over 30 US patents and foreign analogs.

Mr Michael C Vincent: Mr. Vincent is a consulting engineer at Insight Consulting FracWell LLC in Colorado. He holds a Bachelor of Science degree in Chemical Engineering and Petroleum Refining from the Colorado School of Mines. Mr. Vincent has authored over 30 technical papers and has instructed over 250 seminars on fluid flow, fracture design and practical production optimization.

Mr Cameron M Matthews: Mr. Matthews holds a Bachelor of Science degree in Civil Engineering from the University of Manitoba and a Master of Science degree from the University of Alberta. He is a Registered Professional Engineer in Alberta with over 30 years of consulting experience in the upstream oil and gas industry. Mr. Matthews has been employed by C-FER Technologies for the past 35 years. Throughout his career at C-FER, he held various engineering and management positions related to oil and gas technologies.

Mr John Ryberg: Mr. Ryberg holds a Bachelor of Science degree in Mechanical Engineering from the University of Illinois and a J.D. from the University of Wisconsin. He has practiced exclusively in intellectual property law for the past 30 years. Mr. Ryberg has 25 years of experience as in-house counsel for several oilfield service companies with offices in the United States, Europe and Asia.

FEDERAL COURT

SOLICITORS OF RECORD

DOCKETS: T-1741-13, T-1569-15, T-1728-15 AND T-2088-15

DOCKET: T-1741-13

STYLE OF CAUSE: PACKERS PLUS ENERGY SERVICES INC. v
ESSENTIAL ENERGY SERVICES LTD. AND TRYTON
TOOL SERVICES LIMITED PARTNERSHIP

AND DOCKET: T-1569-15

STYLE OF CAUSE: RAPID COMPLETIONS LLC AND PACKERS PLUS
ENERGY SERVICES INC. v BAKER HUGHES
CANADA COMPANY

AND DOCKET: T-1728-15

STYLE OF CAUSE: PACKERS PLUS ENERGY SERVICES INC. AND
RAPID COMPLETIONS LLC v WEATHERFORD
INTERNATIONAL PLC., WEATHERFORD CANADA
LTD., WEATHERFORD CANADA PARTNERSHIP
AND HARVEST OPERATIONS CORP.

AND DOCKET: T-2088-15

STYLE OF CAUSE: PACKERS PLUS ENERGY SERVICES INC. AND
RAPID COMPLETIONS LLC v RESOURCE WELL
COMPLETION TECHNOLOGIES INC. AND
RESOURCE COMPLETION SYSTEMS INC.

PLACE OF HEARING: CALGARY, ALBERTA AND TORONTO, ONTARIO

DATE OF HEARING: FEBRUARY 6-10; 13-16; 21-24; 27-28; MARCH 7-9,
2017

JUDGMENT AND REASONS: O'REILLY J.

DATED: DECEMBER 6, 2017

APPEARANCES:

Robert MacFarlane
Joshua Spicer
Michael Burgess
Donald Cameron

FOR THE PLAINTIFF
(Defendant by Counterclaim)
PACKERS PLUS ENERGY SERVICES INC.

Anthony Prenol
Antonio Turco

FOR THE DEFENDANTS
(Plaintiffs by Counterclaim)
ESSENTIAL ENERGY SERVICES LTD. AND
TRYTON TOOL SERVICES LIMITED PARTNERSHIP

Anthony Creber
William Boyer

FOR THE PLAINTIFFS
RAPID COMPLETIONS LLC AND PACKERS PLUS
ENERGY SERVICES INC.

Dalton McGrath, Q.C.
Michael O'Brien
Sarah O'Grady

FOR THE DEFENDANT
BAKER HUGHES CANADA COMPANY

Robert MacFarlane
Joshua Spicer
Michael Burgess
Donald Cameron

FOR THE PLAINTIFFS
(Defendants by Counterclaim)
PACKERS PLUS ENERGY SERVICES INC. AND
RAPID COMPLETIONS LLC

David Madsen, Q.C.
Evan Nuttall

FOR THE DEFENDANTS
(Plaintiffs by Counterclaim)
WEATHERFORD INTERNATIONAL PLC.,
WEATHERFORD CANADA LTD., WEATHERFORD
CANADA PARTNERSHIP AND HARVEST
OPERATIONS CORP

Robert MacFarlane
Joshua Spicer
Michael Burgess
Donald Cameron

FOR THE PLAINTIFFS
(Defendants by Counterclaim)
PACKERS PLUS ENERGY SERVICES INC. AND
RAPID COMPLETIONS LLC

Andrew Bernstein
Yael Bienenstock
Leora Jackson
Neil Kathol
Laura MacFarlane

FOR THE DEFENDANTS
(Plaintiffs by Counterclaim)
RESOURCE WELL COMPLETION TECHNOLOGIES
INC. AND RESOURCE COMPLETION SYSTEMS INC.

SOLICITORS OF RECORD:

Bereskin & Parr
LLP/S.E.N.C.R.L., s.r.l.
Barristers and Solicitors

FOR THE PLAINTIFF
(Defendant by Counterclaim)
PACKERS PLUS ENERGY SERVICES INC.

Toronto, Ontario

Blake, Cassels & Graydon LLP
Barristers and Solicitors
Toronto, Ontario

FOR THE DEFENDANTS
(Plaintiffs by Counterclaim)
ESSENTIAL ENERGY SERVICES LTD. AND
TRYTON TOOL SERVICES LIMITED PARTNERSHIP

Gowling WLG
Barristers and Solicitors
Ottawa, Ontario

FOR THE PLAINTIFFS
RAPID COMPLETIONS LLC AND PACKERS PLUS
ENERGY SERVICES INC.

Blake, Cassels & Graydon LLP
Barristers and Solicitors
Calgary, Alberta

FOR THE DEFENDANTS
BAKER HUGHES CANADA COMPANY

Bereskin & Parr
LLP/S.E.N.C.R.L., s.r.l.
Barristers and Solicitors
Toronto, Ontario

FOR THE PLAINTIFFS
(Defendants by Counterclaim)
PACKERS PLUS ENERGY SERVICES INC. AND
RAPID COMPLETIONS LLC

Borden Ladner Gervais LLP
Barristers and Solicitors
Calgary, Alberta

FOR THE DEFENDANTS
(Plaintiffs by Counterclaim)
WEATHERFORD INTERNATIONAL PLC.,
WEATHERFORD CANADA LTD., WEATHERFORD
CANADA PARTNERSHIP AND HARVEST
OPERATIONS CORP

Bereskin & Parr
LLP/S.E.N.C.R.L., s.r.l.
Barristers and Solicitors
Toronto, Ontario

FOR THE PLAINTIFFS
(Defendants by Counterclaim)
PACKERS PLUS ENERGY SERVICES INC. AND
RAPID COMPLETIONS LLC

Torys LLP
Barristers and Solicitors
Toronto, Ontario

FOR THE DEFENDANTS
(Plaintiffs by Counterclaim)
RESOURCE WELL COMPLETION TECHNOLOGIES
INC. AND RESOURCE COMPLETION SYSTEMS INC.

Field Law
Barristers and Solicitors
Calgary, Alberta